

TECHNICAL SPECIFICATION SHEET



FOOD WASTE DISPOSERS

The most convenient way to dispose of food waste in your kitchen, including chicken bones, vegetable and fruit peelings and much more.

Food waste disposers provide a safe and environmentally alternative to transporting food waste to landfills.

All disposers are compliant with the EC Directive regards RoHS.

CB Certificate Approval
N° - NO75982

Issued by



NEW MODEL FWD 600 HS- V TYPE

Dimensions (mm.)

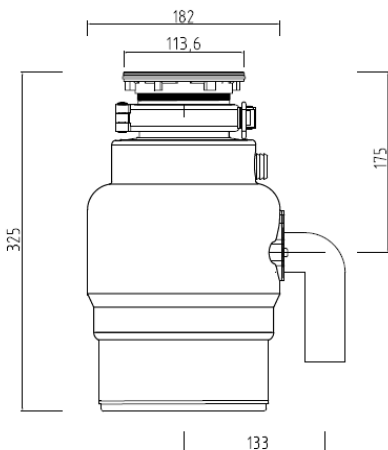

Specifications	
Type of feed	Continuous
Motor type	AC Induction
HP - Watt	3/4 – 600
Volts	220-240
Hz	50
RPM	1410
AMP (avg. load)	4.7A
Motor protection	Manual reset overload
Bearings	Permanently lubricated
Sink Flange	SS AISI 304+Zinc alloy
Sink Stopper	Stainless Steel
Splash Guard	Natural rubber
Casting Grinding Ring	SS AISI 202
Swivel Impellers	SS AISI 202
Turntable	SS AISI 430
Second Turntable	SS AISI 430
Hopper	PA66+GF25%
Drain Housing	ABS
Grind Chamber Capacity	1300ml
Sound Shell	PE
Dishwasher Drain Connection	Yes
Drain Connection	Ø 40 mm.
Disposer weight	8,5 kg.
Power cord attached	Yes
Life Span	10 years
Fitted with a time saving snap-on hinged clamp system for an exclusive and economical installation	

Assembly drawing

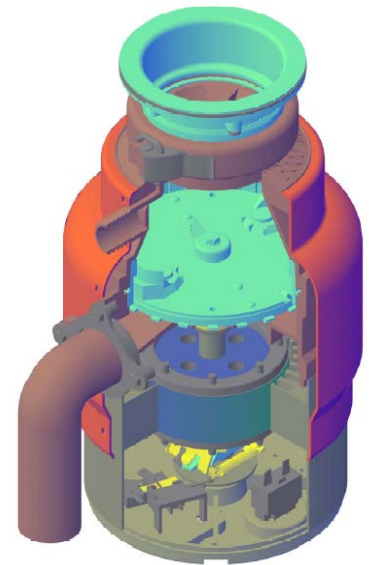
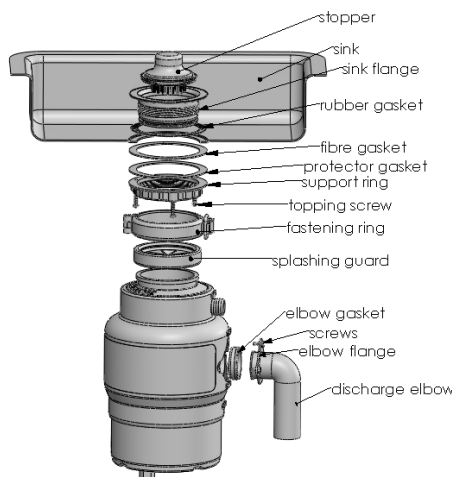

NEW MODEL FWD 600 HS
V TYPE

Air switch system built in